



# DCU150M1224

# DCU150M1224S



## DC-UPS User's Manual

# 1. Table of contents

1. Table of contents.....	2	8. Power Boost.....	23
1.1. Symbols.....	3	9. Battery Start.....	25
1.2. Safety and Warning Notes.....	4	10. Battery Management.....	25
2. Installation Check List.....	5	10.1. Types of Batteries.....	25
3. Description.....	6	10.2. Battery charging.....	25
3.1. General.....	6	10.3. Charging Phases.....	26
3.2. Layout.....	7	10.3.1. Recovery.....	26
3.3. Dimensions.....	8	10.3.2. Bulk.....	26
3.4. Block Diagram.....	9	10.3.3. Absorption.....	26
4. Installation.....	10	10.3.4. Float.....	26
4.1. Normal Mounting Position.....	10	10.4. Battery Tester function.....	26
4.2. Mounting the DC-UPS.....	10	10.5. Battery replacement.....	27
4.3. Removing the DC-UPS.....	10	11. Communication.....	28
5. Connection.....	11	11.1. LED signals.....	28
5.1. Wiring Cables Cross-sections.....	11	11.2. Alarm contacts.....	28
5.2. Mains Input.....	11	11.3. Modbus-RTU.....	28
5.2.1. Primary side protection.....	11	12. Output Configurations.....	31
5.2.2. Mains connection.....	11	12.1. Standard Output configuration.....	31
5.3. Load Output.....	13	12.2. Redundancy Output configuration.....	31
5.4. Battery Output.....	13	12.3. Series Output configuration.....	31
5.5. Alarm contacts connection.....	15	13. Derating.....	33
5.6. SBS Temperature Smart Battery Sensor connection.....	16	13.1. Derating for Ambient temperature.....	33
5.6.1. User defined battery pack.....	17	13.2. Derating for Elevation above sea level.....	33
5.6.2. Aris Power BBX battery pack.....	17	14. Technical Data.....	34
5.7. Data Link Connection.....	17		
6. DC-UPS Configuration.....	19		
6.1. Output Voltage Setting.....	19		
6.2. Maximum Charge Current Setting (7).....	19		
6.3. Battery Type Setting.....	21		
6.4. Buffer Time Setting (5).....	21		
6.5. Fast Charge.....	22		
6.6. Life test.....	22		
7. Operation Modes.....	22		
7.1. Standby Mode.....	22		
7.2. Backup Mode.....	23		
7.3. Power Supply Mode.....	23		

## 1.1. Symbols

Throughout this document, the following symbols will be used to display instructions and possible dangers:



### **NOTE**

When this symbol appears, along with the "NOTE" word, the reader is notified about situation which may cause damage or malfunction to the device, hardware / software, or surrounding property.



When this symbol appears, the reader is provided with additional information or referred to detailed sources of information.



When this symbol appears, safety hazards are involved. Extreme care must be taken as potential personal injury hazards may occur. Comply with all safety measures indicated in the following text to avoid potential personal injuries.

Different categories of personal injuries are indicated by different signaling.



### **WARNING**

This word implies a hazardous situation which, if not prevented, could result in death or serious injury.



### **CAUTION**

This word implies a hazardous situation which, if not prevented, could result in minor or moderate injury.

## 1.2.Safety and Warning Notes



### **WARNING: Electric shock risk!**

- This device must be properly installed, started up, and operated only by qualified technicians.
- Always verify no voltage is present before beginning to work.
- Ensure correct wiring connection and safety regulation compliance to protect against electric shock.
- Connect the protection conductor terminal "PE" with ground.
- Cover terminals' area after installation to avoid accidental contacts with live parts (e. g., installation in control cabinet).



### **WARNING: Explosion Hazard**

Do not disconnect Equipment unless power has been switched off or the area is known to be non-hazardous



### **CAUTION**

Before servicing, disconnect both Mains and the energy storage to de-energize the unit.



### **CAUTION: Fire Prevention**

- Do not place flammable or exploding material nearby the device.
- To reduce the risk of fire, connect only to a circuit provided with a maximum branch circuit overcurrent protection in accordance with the Norms.
- To reduce the risk of fire, replace only with same type and rating of fuse.



### **CAUTION: Hot Surface**

- Both the ambient temperature and heat losses due to the load operation may overheat the device housing surfaces.
- Ensure sufficient convection (minimum gap above/below: 50 mm), sides 10 mm.



### **NOTE: Battery Connections**

When batteries are being connected, check for correct polarity. Make sure not to short circuit the battery terminals.



### **NOTE: Wiring selection**

- Copper cables must be used for operating temperatures above 75 °C.
- Refer to the associated table for the connection parameters, such as the necessary stripping length for the wiring with and without ferrule (see section Wire cross sections).



### **NOTE: General Installation Notes**

- National safety and accident prevention guidelines must be followed according to UL508 or UL60950.
- Assembly and electrical installation must correspond to the state of the art.
- The DC-UPS is a built-in device. The protection class of the device is IP20. It is meant to be installed in a clean and dry environment.
- Protect the device against foreign bodies penetrating it, e.g., paper clips or metal parts.
- The device must be installed in a control cabinet that can be locked and only opened by specialist staff.
- Vertical mounting is the normal and only authorized mounting position.
- Observe mechanical and thermal limits.



### **NOTE: Protections Selection**

- Install a switch/circuit breaker close to the device at the Mains input, Load output and at the battery terminals which are labeled as the disconnecting device for this device.
- Ensure that the primary-side wiring and secondary-side wiring are the correct size and have sufficient fuse protection.
- Do not disconnect the fuse and/or battery connection when in hazardous locations.
- Use current-limited source or suitable fuse.
- The switching outputs are active outputs according to SELV. These may only be operated on permitted SELV circuits.



- The device is maintenance-free. Repairs may only be carried out by the manufacturer. The warranty no longer applies if the housing is opened.
- The device may only be used for its intended use.
- Improper use invalidates the device protection.
- Keep these instructions in a safe place – it contains important safety notes which must be observed during installation and maintenance of the DC-UPS devices and batteries.

## 2. Installation Check List

Please carefully follow this check list during installation. We suggest printing Table 1, fill out and file it as installation report. Add notes as felt necessary.

Table 1 - Installation Device Check List.

<b>Device: DCU150M1224S</b>		<b>Ref:</b>		
<b>Item</b>	<b>Action</b>	<b>Setting device Reference</b>	<b>✓</b>	<b>Notes</b>
1	Read Safety and Warning notes	Chapt. 1		
2	<b>Set Output Voltage, 12V or 24V</b>	<b>Dipswitch 1</b>		
3	Set Maximum Charge Current	Selector 7, Chapt. 6.2		
4	Mount the DC-UPS	Chapt. 4		
5	Wire the DC-UPS	Chapt. 5.1		
5.1	Wire Mains	Chapt. 5.2		
5.2	Wire Load	Chapt. 5.3		
5.3	Wire Battery	Chapt. 5.4		
5.4	Wire Alarm contacts	Chapt. 5.5		
5.5	Wire SBS Temperature sensor	Chapt. 5.6		
5.6	Wire Data Link	Chapt. 5.7		
6	Configure the DC-UPS	-		
6.1	Set Battery Type	Dipswitch 2-3-4, Chapt. 6.3		
6.2	Set Buffer Time	Selector 7-8, Chapt. 6.4		
6.3	Enable or disable Fast Charge	Dipswitch 5, Chapt. 6.5		
6.4	Enable or disable Life Test	Dipswitch 6, Chapt.6.6		

## 3. Description

### 3.1. General

Congratulation for choosing an Aris Power innovative, high performance and safety power product. Install it in your application to achieve higher reliability and extended lifetime.

This is the user manual of **DCU150M1224** and **DCU150M1224S**, a **150 W DC-UPS** belonging to the DCU Series of AC/DC Uninterruptable Power Supply systems. Its mission is providing Power Security to critical DC loads. For flexibility of use, it features selectable output voltage, 12 Vdc or 24 Vdc, via dipswitch. Input is very flexible and can be AC or DC

Main Features - Designed following a mains-connected, on-line, All-in-One architecture, the device contains:

- Power supply + Back-up Module + Battery Charger + Battery Monitoring + Battery Tester, all packaged in one box;
- Its wide input range makes it suitable for connection to mains with 115–230-277 Vac single-phase voltage rating or 110-240 Vdc;
- Load-first, Dynamic Load/Battery power sharing logic;
- In Power Boost Mode it can deliver up to 4 times the rated current. It is therefore uniquely suitable to backing up DC loads with high inrush current;
- Buffer time setting of load backup;
- Manual Battery start-up with no mains via push button;
- Full set of protections. Both Load and Battery outputs are protected against overload and short circuit. On safety grounds, the **battery output is disabled when the battery is disconnected**;
- Adjustable maximum charging current to protect the battery against overcurrent damages;
- Remote alarms via 3 dry relay contacts;
- Standby/Backup;
- Battery Low & Common Fault;
- Rectifier Failure;
- Smart Battery Sensor (SBS) for temperature compensation via USB port;
- Battery management is performed by Aris Power BattSafe, a comprehensive battery management firmware. BattSafe includes:
- Universal Charger with factory-set charging curves for the most common battery types: Vented Lead Acid, VRLA, Valve Regulated AGM or Gel Lead Acid, Ni-Cd, Li-Io;
- Flat batteries which are not irreversibly damaged can be recovered;
- Real time diagnostic during installation, preventing installation errors;
- Continuous battery monitoring during operation, minimizes the risk of battery damage and allows a fully safe operation while keeping battery in permanent connection with the DC-UPS. Extended battery life is the result;
- Device and system faults are also detected by auto-diagnostic features;
- Battery Tester - Life test can be activated manually through a dedicated push button, to facilitate maintenance checks;
- All status and faults signals are shown on the front panel LEDs;
- Data Link Communication (DLC), on devices with this feature, allows availability of status and faults signals also in remote mode. **DCU150M1224S only**.

### 3.2. Layout

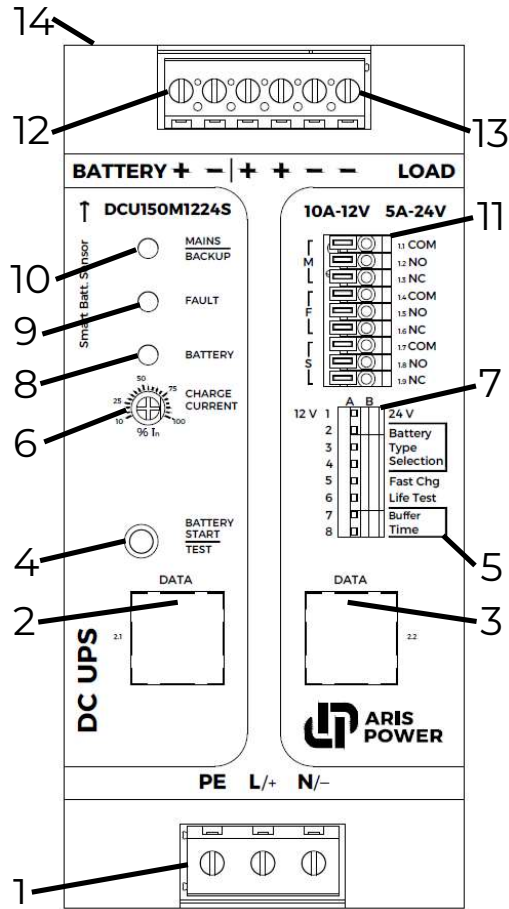

Figure **Error! No text of specified style in document..1** – Device layout.

N.	Description	N.	Description
1	INPUT VOLTAGE TERMINALS	8	BATTERY STATUS LED
2	CAN BUS/MODE BUS RJ45 CONNECTOR 1	9	FAULT LED
3	CAN BUS/MODE BUS RJ45 CONNECTOR 2	10	MAINS/BACKUP LED
4	BATTERY START/TEST PUSH BUTTON	11	ALARMS PUSH-IN TERMINALS
5	BUFFER TIME SETTING	12	BATTERY OUTPUT TERMINALS
6	CHARGE CURRENT TRIMMER	13	LOAD OUTPUT TERMINALS
7	FUNCTIONS DIP-SWITCHES	14	SENSOR FOR BATTERY TEMPERATURE COMPENSATION (UART CONNECTOR)

### 3.3. Dimensions

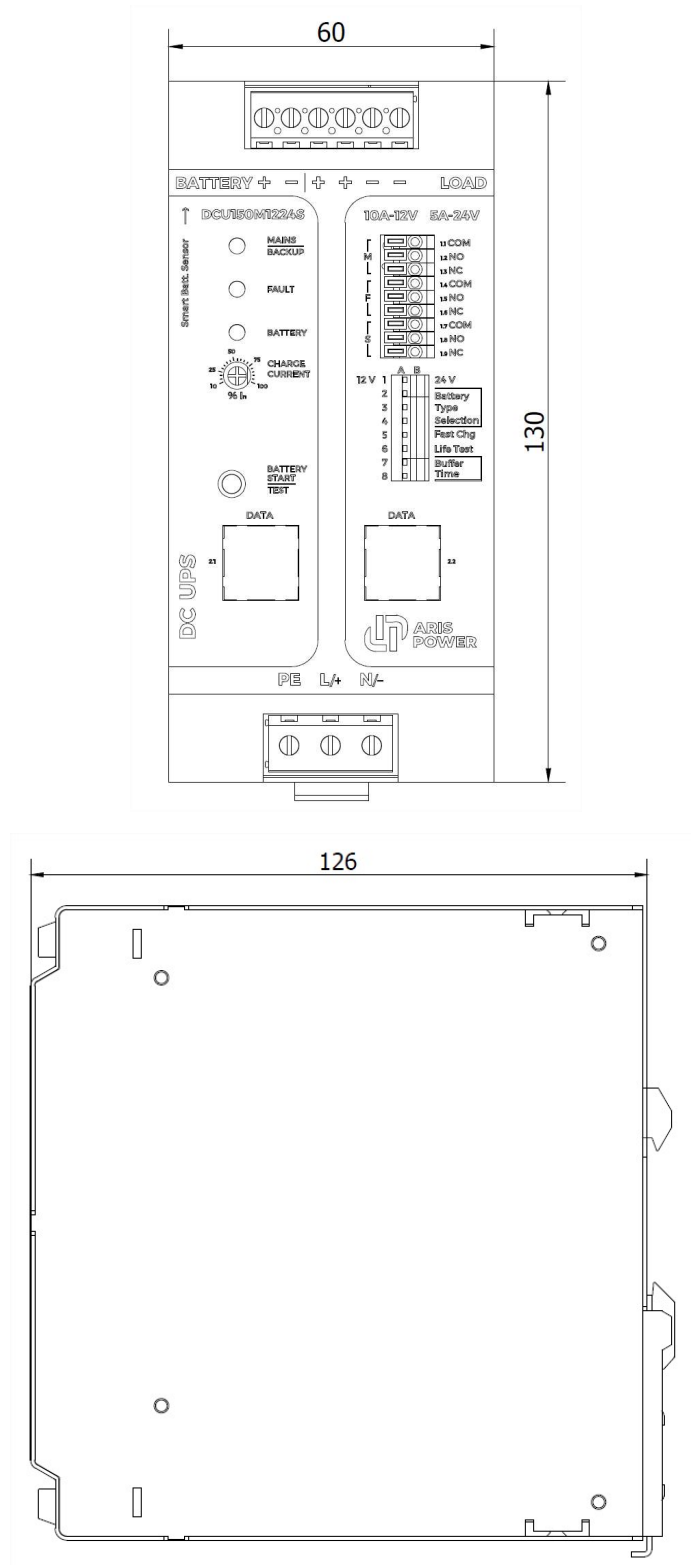

Figure **Error! No text of specified style in document.**2 – Side and front views.



### 3.4. Block Diagram

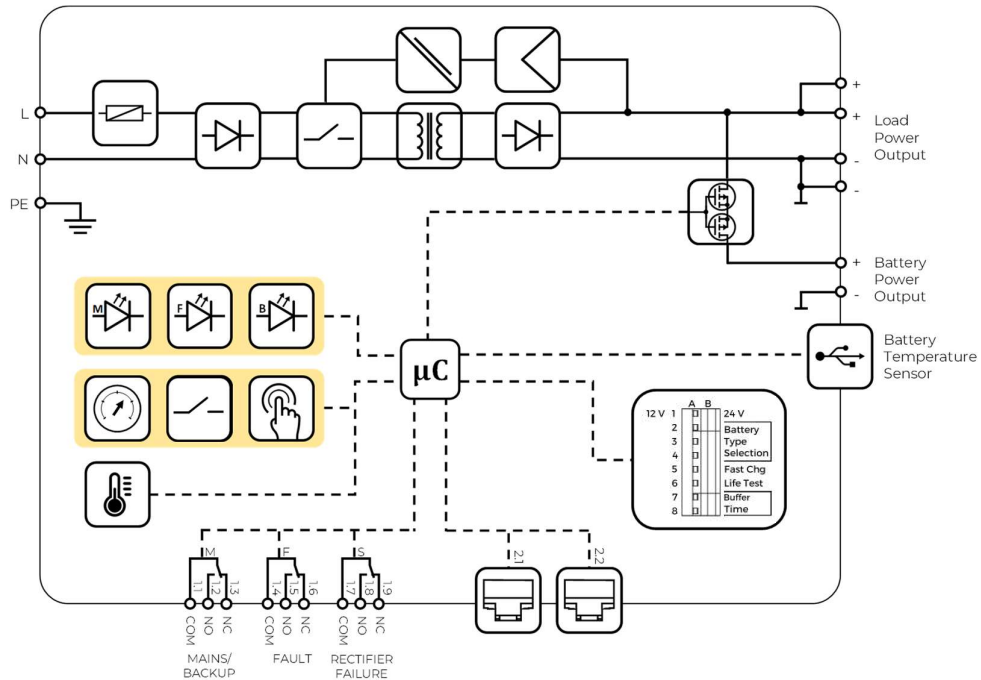

Figure **Error! No text of specified style in document.**3 - Device block diagram. Black continuous lines represent power connections, dashed lines indicate functional links.

Block	Description	Block	Description
	Buffer Time Dipswitch		Rectifier
	Max Current Setting		Regulator
	Electrically Isolated Signal Transmission		RJ45 Serial Communication
	Fuse		Smart Battery Sensor UART USB
	LED - Battery		Safety Switch
	LED - Fault		Supply Swapping Switch
	LED - Mains/Backup		Temperature Protection Sensor
	Microcontroller		Transformer
	Battery Start / Test Push Button	-	-

## 4. Installation

### 4.1. Normal Mounting Position

The device can be snapped onto all DIN rails according to EN 60715 and should only be mounted in the normal mounting position, as shown in Figure **Error! No text of specified style in document..4**.

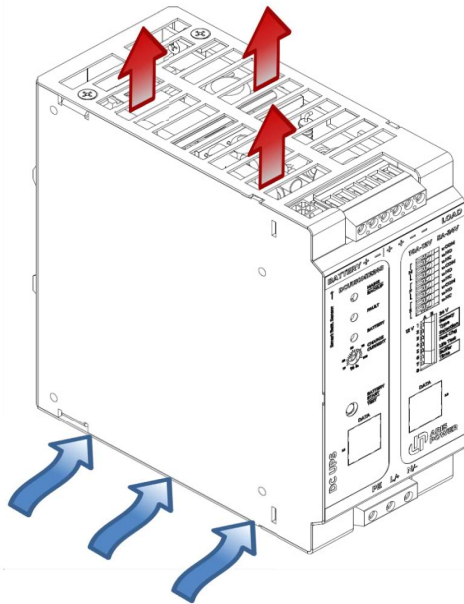

Figure **Error! No text of specified style in document..4** – Device mounting position.



#### NOTE

- The device must be installed in a control cabinet that can be locked and only opened by specialist staff.
- The device must be installed at least 10 mm apart from all other devices to allow proper ventilation. While in operation, be aware that the temperature of the external case can become very high depending on load / battery current and ambient temperature

### 4.2. Mounting the DC-UPS

To mount the device, proceed as follows:

1. In the normal mounting position, the device is mounted on the DIN rail from above. Make sure that the DIN rail bracket is in the correct position above the DIN rail.
2. Place a suitable screwdriver on the tab of the DIN rail bracket.
3. Pull the tab down by lifting the screwdriver.
4. Press the device down until the bracket snaps into place.
5. Check that the device be securely fastened onto the DIN rail

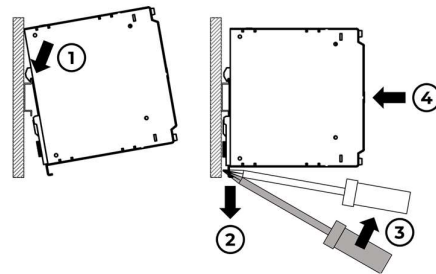

Figure **Error! No text of specified style in document..5** – Mounting the device.

### 4.3. Removing the DC-UPS

To remove the device, proceed as follows:

1. Place the screwdriver on the tab of the DIN rail bracket.
2. Unlock the tab from the DIN rail by lifting the screwdriver.
3. Carefully pull the lower part of the device forward so that the tab slides back into the initial position.
4. Remove the device from the DIN rail

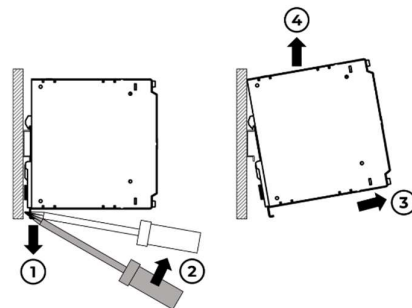

Figure **Error! No text of specified style in document..6** – Removing the device.

## 5. Connection

### 5.1. Wiring Cables Cross-sections

For connection use copper wires only, suitable for minimum 75°C. Wiring terminals shall be marked according to best industry practice to indicate proper connection to and from the DC-UPS.

Table 2 - Cable cross-sections to be used for wiring.

Connect to	Terminal Type	Solid (mm <sup>2</sup> )	Stranded (mm <sup>2</sup> )
Mains	Screw	0.2 - 2.5	0.2 - 2.5
Load	Screw	0.2 - 2.5	0.2 - 2.5
Battery	Screw	0.2 - 2.5	0.2 - 2.5
Signals	Push in	0.2 - 1.0	0.2 - 1.0

Connect to	AWG	Torque (Nm)	Stripping Length (mm)
Mains	26 - 12	0.5 - 0.6	7
Load	26 - 12	0.5 - 0.6	7
Battery	26 - 12	0.5 - 0.6	7
Signals	24 - 20	0.5 - 0.6	11

### 5.2. Mains Input

AC or DC mains input is connected via the terminals at the bottom of the DC-UPS.

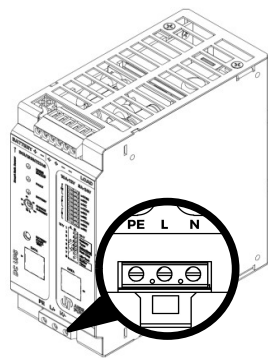

Figure Error! No text of specified style in document..7 - Mains input connection.

#### 5.2.1. Primary side protection

To switch on / off the device, a proper disconnection device must be installed on the mains connection. This function can be performed by the recommended primary-side line protection, either a delayed Fuse or an MCB, curve C.

The device is also protected against device faults. by an internal fuse.

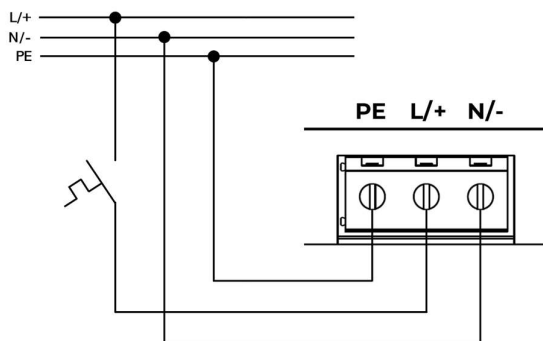

Figure Error! No text of specified style in document..8 – Primary side protection.



If, due to a device fault, the internal fuse trips, the device must not be opened. It must be returned for factory inspection. Un-authorized opening or repairing of the device is not allowed and would void the guarantee coverage.

#### 5.2.2. Mains connection

The DC-UPS can be operated on AC single-phase and DC power grids in accordance with the rated input voltage. Connection is via the input L/+ N/- PE terminals.

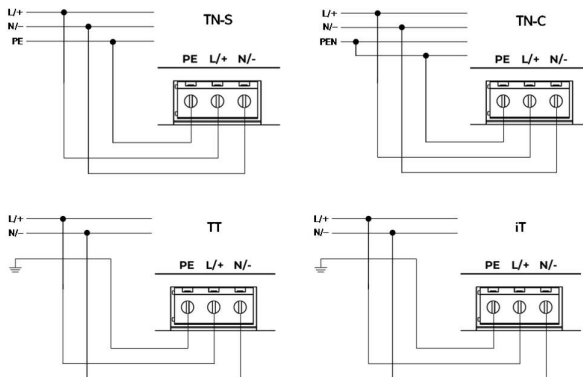

Figure **Error! No text of specified style in document.**9 – Mains connection.

### 5.3. Load Output

Buffered loads are connected to the DC-UPS on the LOAD output terminals. There are two plus (" + ") and two minus (" - ") terminals available. Use a 3 mm flat-head screwdriver.

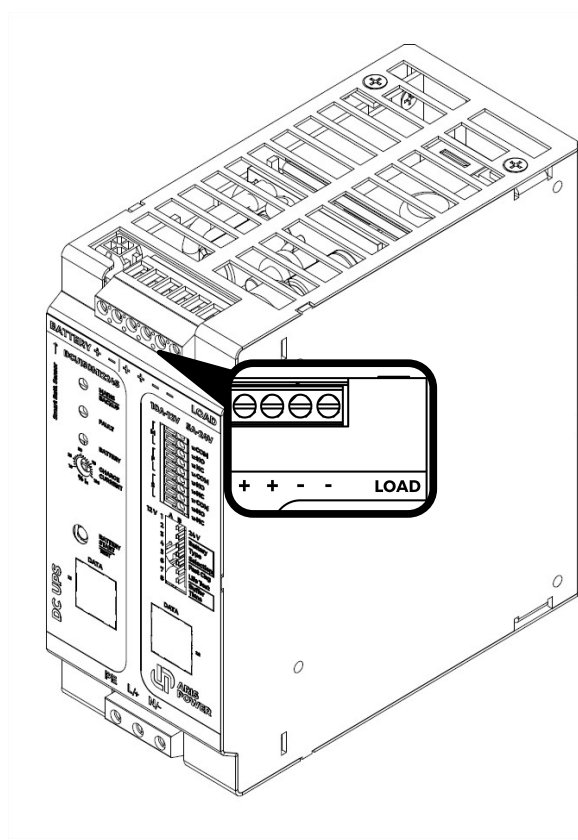

Figure **Error! No text of specified style in document..10** -Load connection.

Load output cables must be properly dimensioned for the maximum output current. They should also have a large cross section to keep voltage drop as low as possible.

### 5.4. Battery Output

The BBX battery module or customer own battery module is connected to the DC-UPS via the first two terminals in the upper terminals area. Use a 3 mm flat-head screwdriver.

Battery output cables must be properly dimensioned for the maximum output current. They should also have a large cross section to keep voltage drops as low as possible.

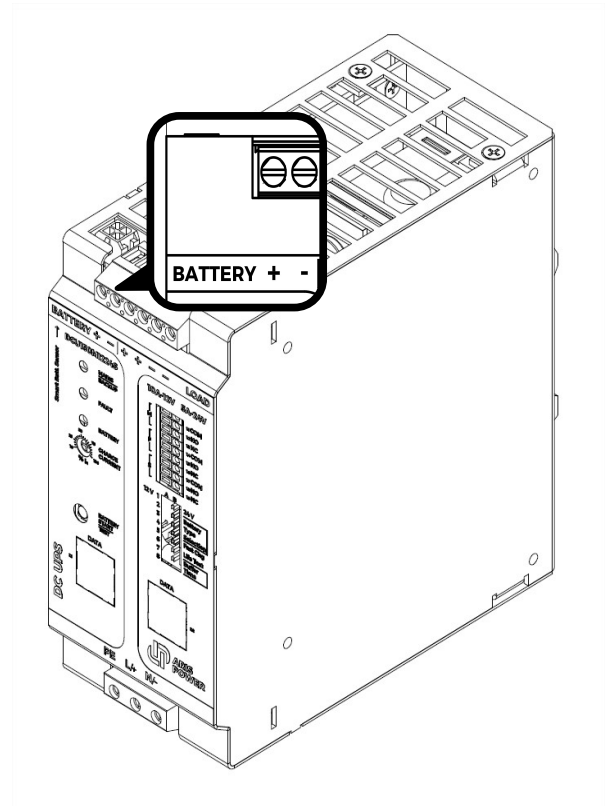
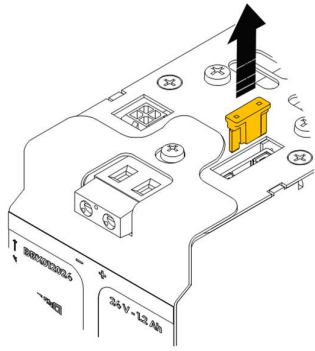

Figure **Error! No text of specified style in document..11** – Battery connection.

Connection to the Battery must be done according to the following instructions:

1. The DC-UPS must be switched off before connecting the battery.
2. Install the Battery Box as close as possible to the DC-UPS
3. Open the front cover of the housing.
4. Remove the fuse (see Figure **Error! No text of specified style in document..11a**).
5. Connect the wiring between the DC-UPS and the Battery Box
6. Insert back the fuse (see Figure **Error! No text of specified style in document..11b**).
7. Close the front cover.
8. Secure the housing to prevent it from being opened.
9. Power up the DC-UPS



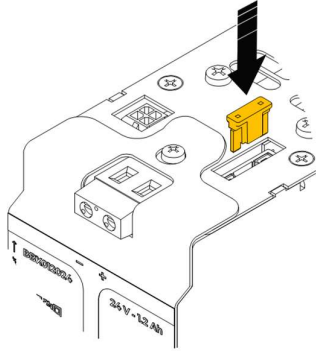

Figure **Error! No text of specified style in document.**12 – BBX Battery box: a) Removing and b) Inserting fuse.



**WARNING**

- When connecting the batteries take note of the polarity.
- Do not short circuit the pole terminals.
- The batteries are maintenance free and may not be opened.



**NOTE**

**Risk of short circuit** - When installing or replacing the battery, the fuse of the battery module must be removed. This will prevent the risk of short circuit and ensure safety for the operator.



**NOTE**

Before storing Battery modules, note the latest recharge or recharge it, if necessary.

## 5.5. Alarm contacts connection

The DC-UPS is equipped with three built-in alarms, as follows:

- Mains/Backup
- Battery Fault
- Rectifier Failure

The three alarms are on dry change-over relay contacts and are brought to push-in terminals on the front of the device.

Connect the push-in terminals using wiring cables according to above given instructions.

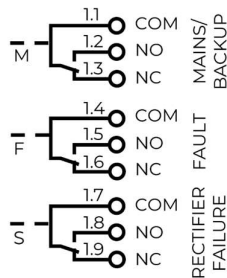
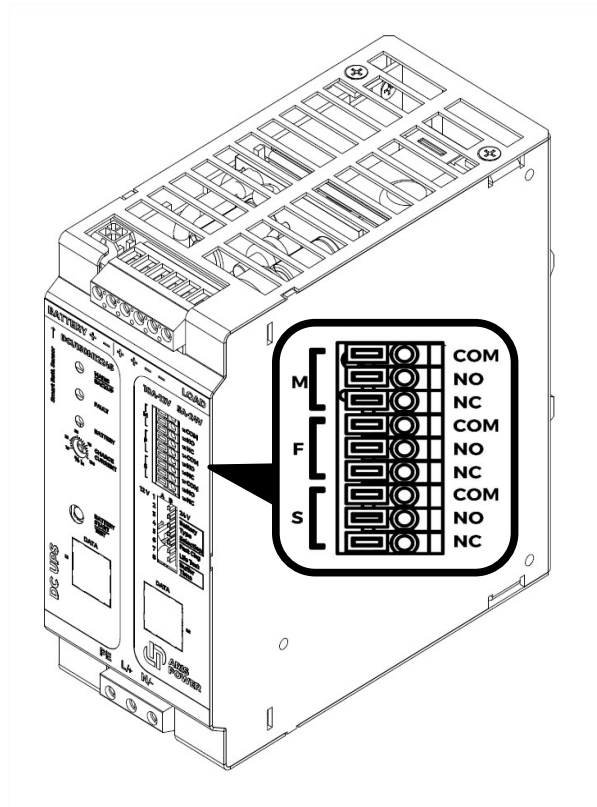

Figure **Error! No text of specified style in document.**13 – Alarm contacts connection.

## 5.6. SBS Temperature Smart Battery Sensor connection

The SBS sensor is necessary when battery temperature compensation of charging voltage is required by the norms.

The DC-UPS is designed to perform temperature compensation battery charging voltage in compliance with the specifications of EN54-4 fire protection norm or other international equivalent norms, as follows



Table 3 - Battery Charging Voltage Compensation as a function of Temperature deviation from 20 °C (\*).

Parameters	Fast Charge	Float charge
$\frac{\Delta U}{^{\circ}\text{C}\cdot\text{Cell}}$	$\pm 5 \text{ mV}$	$\pm 3 \text{ mV}$
Temperature range	-8 °C to +60 °C	-20 °C to +60 °C
$\frac{\Delta U}{\text{Cell}}$	+140mV / -200mV	+120mV / -120mV
Reference temperature	+20 °C	+20 °C

(\*) These values do not apply to Lilon and NiCd batteries.

### 5.6.1. User defined battery pack

To activate this function, locate the UART connector on top of the device. Connect the SBS001 cable (separate article, not included) to the device and to the battery. Once connected, the device will self-configure to perform battery voltage temperature compensation.

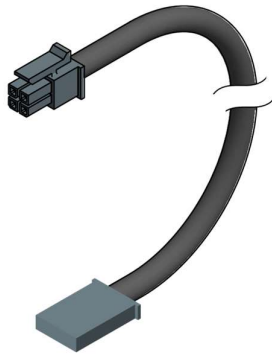

Figure Error! No text of specified style in document..14 - SBS001 Temperature Smart Battery Sensor for user defined battery pack with cable.

### 5.6.2. Aris Power BBX battery pack

In case a BBX with built-in Temperature Smart Battery Sensor is designed in the system, to activate this function, locate the UART connector on top of the device. Connect the SBS002 cable (separate article, not included) to the device and to the BBX Battery pack. Once connected, the device will self-configure to perform battery voltage temperature compensation.

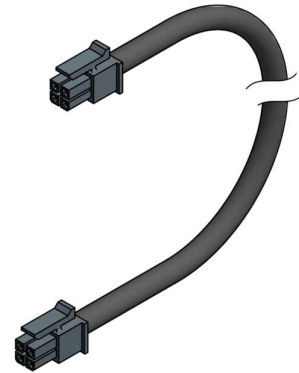

Figure Error! No text of specified style in document..15 - SBS002 Temperature Smart Battery Sensor for BBX battery pack with cable.

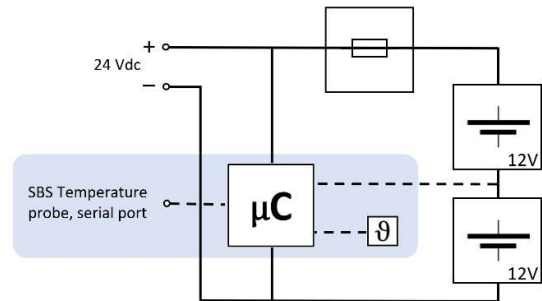
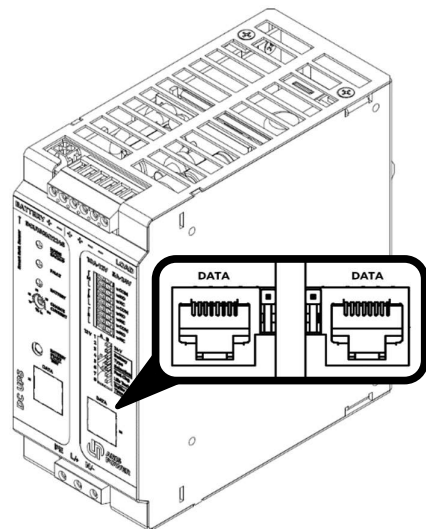

Figure Error! No text of specified style in document..16 - Smart Battery Sensor Scheme.

## 5.7. Data Link Connection

### DCU150M1224S only

To activate this function, locate the RJ45 connectors on the front of the device. Connect the DLC001 cable (separate article, not included) to the device and to the Custom logic unit. The device will self-configure.





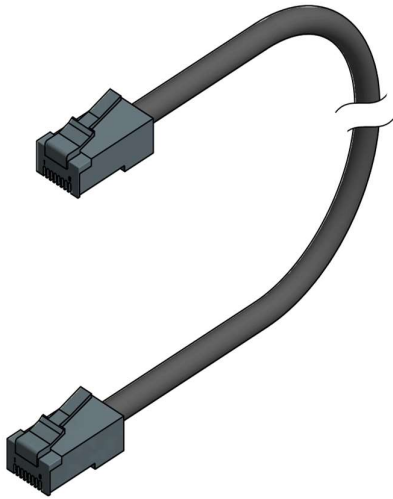

Figure Error! No text of specified style in document..17 – a) Data Link connectors and b) DLK001 connecting cable.

## 6. DC-UPS Configuration

Before powering on, the DC-UPS must be configured via the selectors and dipswitches on the front panel.

### 6.1. Output Voltage Setting

This is a Selectable Output Voltage DC-UPS device, 12 Vdc or 24 Vdc.

Before powering on the device, it is fundamental to select the correct output voltage to match load and battery rated voltage.



#### WARNING

- Special care must be paid when setting this parameter since a wrong configuration may cause damages to load and battery.
- Do not change dipswitch 1 position while the device is energized. It might cause damages to load and battery. If in need to do so, power off the device first.

Factory setting is 12 Vdc. This corresponds to top dipswitch n. 1 in position A.

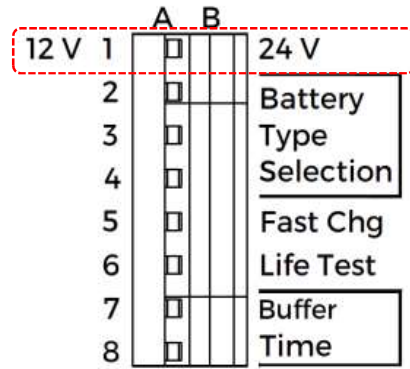

Figure Error! No text of specified style in document..18 - Setting Output Voltage.

In case 24 Vdc is required, before powering on the device, move dipswitch n. 1 to position B.

### 6.2. Maximum Charge Current Setting ( 7 )

It is a key setting in enabling a safe and extended battery lifetime. Adjustment of the maximum Charge Current selector allows to protect the battery from excessive charging currents.

To determine this value, refer to the battery manufacturer's datasheet. If this is not available, consider a maximum charge current in the range between 1/10 and 1/8 of battery rated capacity given in Ah. (Example: for a 10 Ah battery = 1.0 – 1.3 A). This approximate value is suitable for Lead Acid and NiCd but not necessarily for other types of batteries.

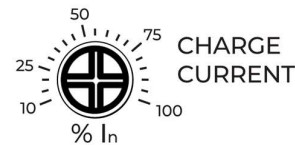

Figure Error! No text of specified style in document..19 – Maximum Charge Current Setting.

To select the desired maximum charge current, rotate the corresponding selector (7). Current can be set between 10-100% of DC-UPS nominal current. Factory setting is 10%.



Battery charging current is capped by the maximum charging current set on the selector (7).



### 6.3. Battery Type Setting

This device allows different battery charging operations based on the installed battery type. To select the correct type, the 3rd, 4th and 4th dipswitch must be configured according to the following table.

**WARNING**

Switch off the system before selecting battery type on the dipswitch.

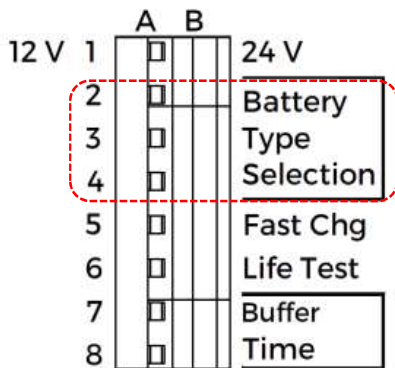

Figure Error! No text of specified style in document..20 – Battery Type setting.

Table 4 - Battery type selection via Dipswitch.

Dipswitch Position	Battery Type				
	Vented Lead	VRLA AGM Lead	VRLA Gel Lead	Li-ion	Ni-Cd, Ni-Mh
Dip 2	A	B	B	A	B
Dip 3	A	B	A	B	A
Dip 4	A	A	B	B	A

Factory setting is always Vented Lead. This corresponds to dipswitch n. 2, 3, 4 in position A.

### 6.4. Buffer Time Setting (5)

Different buffer times can be set via the Buffer Time double dipswitch set on the device (5). Four positions are available. The selector default factory set position “A A”, meaning that load will be fed until the battery voltage

reaches the Low Voltage Disconnect (LVD) value. Below this value, the device will autonomously switch off to prevent unnecessary discharge and consequent shorter battery life. In case the buffer time dipswitches are set at a different position, the device will switch off after the corresponding time has elapsed, as shown in the table below.

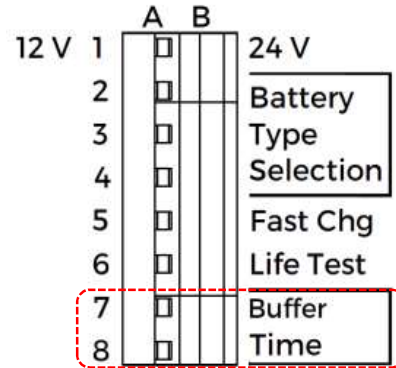

Figure 6.4 – Buffer Time setting.

Table 5 - Buffer Time selection via Dipswitch

Dipswitch Position	Buffer Time (minutes)			
	LVD	180 min	30 min	3 min
Dip 7	A	A	B	B
Dip 8	A	B	A	B

The maximum Buffer Time duration depends on the battery capacity rating and status of charge. Assuming backup occurs when the battery is fully charged, the times given in the table below can be used as reference.

Table 6 - Typical max buffer time with Aris Power Battery Boxes BBX Series, 24 V.

Load Current (A)	Buffer Time (min)		
	BBX012024 1.2 Ah	BBX034024 3.4 Ah	BBX072024 7.2 Ah
1.5	20	60	200
3	8	30	120
5	3	15	55
7.5	2	10	30
10	NA	7	20
15	NA	NA	9
20	NA	NA	7

Load Current (A)	Buffer Time (min)	
	BBX120024 12.0 Ah	100 Ah
1.5	400	NA
3	240	NA
5	100	NA
7.5	60	NA
10	45	1200
15	20	400
20	12	240

## 6.5. Fast Charge

To speed up the battery charging process, the Fast Charge function can be selected, hence applying the bulk voltage on the battery. To enable this function, the corresponding dip-switch n. 5 must be set at position B.

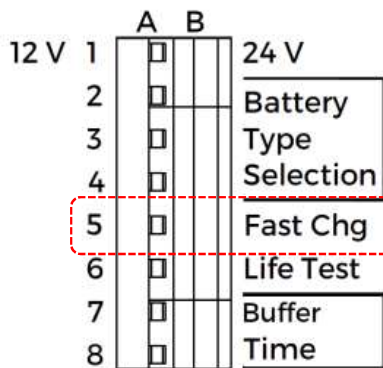
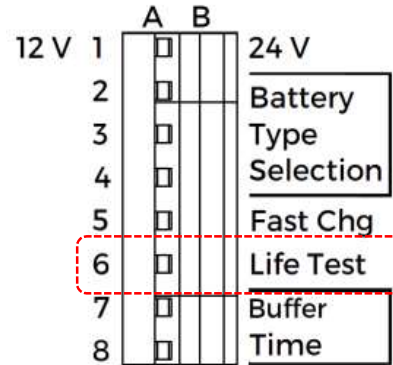

Figure Error! No text of specified style in document..21 – Fast Charge setting.

Factory setting is Fast Charge OFF. This corresponds to dipswitch n. 5 in position A

## 6.6. Life test

The Life test function allows to perform a diagnosis of the battery and to get notified whether the battery is in a good or a bad condition.



Factory setting is Life Test OFF. This corresponds to dipswitch n. 8 in position A.

## 7. Operation Modes

### 7.1. Standby Mode

This is the default status of the device. When mains is present and the battery is present and connected, the device sets automatically to Standby Mode.

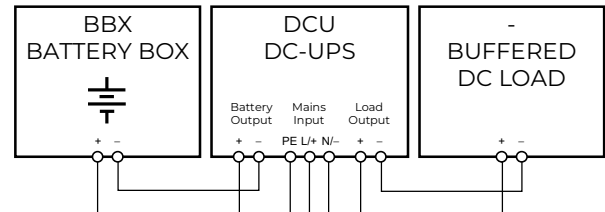

Figure Error! No text of specified style in document..22 – Standby Mode.

In this mode, load output voltage follows the battery voltage. Current sharing between load and battery is autonomously managed by the device, always giving priority to load demand.

#### Signaling

With mains present, the Mains/Backup LED (11) will be set on a steady green color.

#### Overload and Short Circuit protection

If the load demand increases, taking the current value up to its short circuit threshold, the short circuit protection will trigger. Both Overload and Short circuit conditions will be

shown by the common FAULT LED and status change of F Relay output.

## 7.2. Backup Mode

When the battery is connected and charged, in case mains either fails, falls below a threshold value (50% of the rated input voltage) or is anyhow not present, the device sets automatically to Backup Mode. The battery is immediately connected to the load output, without any interruption.

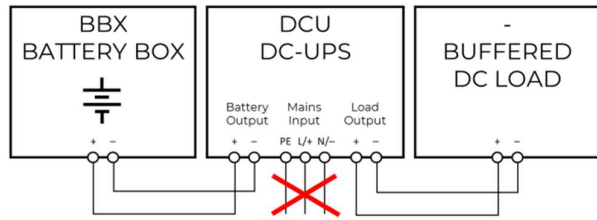

Figure Error! No text of specified style in document..23 – Backup Mode.

From this moment on, the battery is entirely in charge of supplying power to the load. During this mode, load output voltage will follow battery voltage while it discharges. The current going to the load is limited in time according to the battery status of charge.

### Signaling

This condition is shown by a Orange light on the Mains/Backup LED and a status change of (M) relay output.

### Overload and Short Circuit Protection

While in Backup the load and the DC-UPS will be protected against overload and short circuit as in the above Table. Both Overload and Short circuit conditions will be shown by the common FAULT LED and status change of F Relay output.

## 7.3. Power Supply Mode

When mains is present and the battery is either absent, faulty, or disconnected, the device turns into Power Supply Mode. In this case, load output voltage is stabilized at the selected rated value. Available output current is completely absorbed by the load.

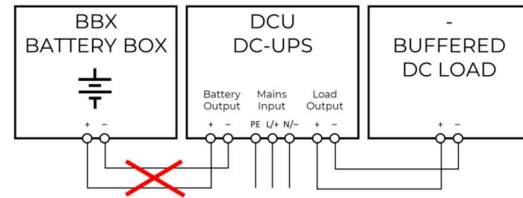

Figure Error! No text of specified style in document..24 – Power Supply Mode.

### Signaling

This condition is shown by a RED light on the FAULT LED and status change of F Relay output.

### Overload and short circuit protection

During Power Supply mode, if the load demand increases, the DC-UPS can take an overload up to 20% of its nominal current. This corresponds to the short circuit threshold. Above this value, the short circuit protection will trigger, as shown in the figure below. Both Overload and Short circuit conditions will be shown by the common FAULT LED and status change of F Relay output

## 8. Power Boost

Since the priority task of the DC-UPS is ensuring the continuity of load power supply, the current delivered to the battery may vary to accommodate load demand first.

The current to the load will follow the demand of the load. When the load demands more than rated, Power Boost is enabled. Under this condition, battery charging will stop or be limited, and the battery will start instead contributing to the load power supply. The total current going to the load is limited in time according to overload current intensity.

During Standby mode, part of the Boost power will come from the mains via the device power supply circuit, part will come from the battery.

During Backup mode all Boost power will come from the battery.

Unless the device is in Power Supply mode (i.e., without battery), when Boost is equal to +20% of IR. during the other modes, if the battery is fully functional, Power boost will be as follows.

Table 7 - Power Boost while in Standby or Backup modes.

Load Current	12 V	24 V
--------------	------	------

Rated	10 A	5 A
Continuous	15 A	10 A
< 30 sec	17 A	15 A
< 15 sec	20 A	20 A
< 5 sec	25 A	25 A



## 9. Battery Start

When mains voltage is not available, and the load must be powered up from the battery, the DC-UPS must first be started using the Battery Start push button ( 5 ).



Figure **Error! No text of specified style in document.**25 -Battery Start ( 5 ).

Keeping the Battery Start button pressed for 2 s, the three LED will turn on in orange color, the DC-UPS will power-on and power the load under the same conditions as in Backup Mode.

This is a facility particularly useful during commissioning if mains is not available to test load operation.

## 10. Battery Management

### 10.1. Types of Batteries

BATTSAFE firmware includes factory-set charging curves for the most common battery types: Vented Lead Acid, AGM and Gel Lead Acid, Ni-Cd, Li-Io.

Lead Acid batteries follows a 4-stage charging curve: IUoU (Bulk, Absorption, Float) plus Recovery stage for deeply discharged batteries.

Charging curves can be selected by dipswitch (see Chapt. 6.3). They can also be customized via Data Link.

Table 8 - Charging voltage for battery type.

Battery Type	Charging Voltage (V/cell)	
	Float	Bulk
<b>Vented Lead</b>	2.23	2.4
<b>VRLA AGM Lead</b>	2.27	2.4
<b>VRLA Gel Lead</b>	2.3	2.4
<b>Li-ion</b>	3.45 <sup>(1)</sup>	3.65 <sup>(1)</sup>

Ni-Cd, Ni-Mh	1.40 <sup>(2)</sup>	1.50 <sup>(2)</sup>
--------------	---------------------	---------------------

Note:

<sup>(1)</sup> 12 V : 4 cells, 24 V : 8 cells;

<sup>(2)</sup> 12 V : 10 cells, 24 V : 20 cells, 48 V : 40 cells.



The Charge Current trimmer (6) allows to select the maximum charging current from the device to the battery. This is a critical setting to protect the battery

### 10.2. Battery charging

Battery management is performed by Aris Power BATTSAFE, a comprehensive battery management firmware based on algorithms for automatic and optimized battery charging.

BATTSAFE includes:

- Universal Charger with factory-set charging curves for the most common battery types: Vented Lead Acid, AGM and Gel Lead Acid, Ni-Cd, Li-Io;
- flat batteries which are not irreversibly damaged can be recovered;
- real time diagnostic during installation, preventing installation errors;
- continuous battery monitoring during operation, to minimize the risk of battery damage and allow a fully safe operation while keeping battery in permanent connection with the DC-UPS. Extended battery life is the result;
- Device and system faults are also detected by auto-diagnostic features;
- Battery Tester - Life test can be activated manually through a dedicated push button, to facilitate maintenance checks;
- All status and faults signals are shown on the front panel LEDs;
- Data Link Communication (DLC), on devices with this feature, allows availability of status and faults signals also in remote mode.

BATTSAFE can diagnose battery fault conditions, among them:

- Battery cells in short circuit;
- Sulfated battery;
- Reverse polarity connection;
- Battery missing or disconnected.

## 10.3. Charging Phases

All Lead-Acid battery charging curves share the same charging phases.

DCU operate as an Automatic multi-stage charger following a stabilized voltages and stabilized current IUoU curve. The 5 charging phases are identified by a flashing code on the Battery LED.

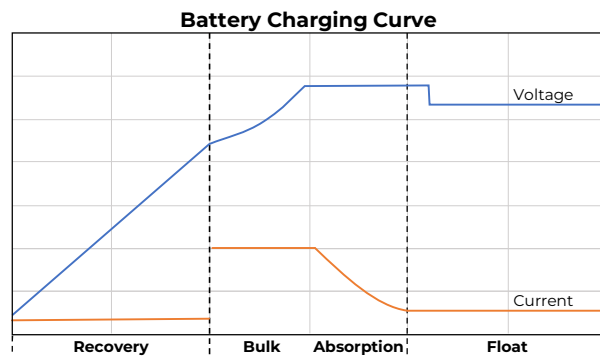

Figure **Error! No text of specified style in document.**26 – Battery Charging Curve

### 10.3.1. Recovery

This charging phase is used to recover deeply discharged batteries. During this phase, a constant current is applied to the battery. If the battery is still in good conditions the battery voltage will increase and eventually reach 1.67 V/cell (10 V at  $U_n=12$  V or 20 V at  $U_n=24$  V). Once reached this value the charge mode will automatically transfer to Bulk charge mode. The minimum duration of this phase is 5 s. Timeout is set at 120 min. If instead after 120 min the 1.67 V/cell level is not reached, this means that the battery cannot be recovered. The DCU will signal fault on the Fault LED and F Relay contact.

### 10.3.2. Bulk

The battery enters Bulk phase either after reaching 1.67 V/cell (10 V at  $U_n=12$  V or 20 V at  $U_n=24$ ) if coming from Recovery mode or after falling below 2.1 V/cell (12.6 V at  $U_n=12$  V or 25.2 V at  $U_n=24$  V) while in Float mode. During this charging phase the current is kept constant at its maximum value set on trimmer (7).

Once Bulk voltage is reached, the battery will enter in Absorption phase. The minimum duration of this phase is 5 s.

Timeout is set at 900 min. After this time, charging will automatically transfer to Absorption charge mode.

### 10.3.3. Absorption

During this charging phase, with Fast Charge enabled, the voltage is set equal to 2.375 V/cell, while the current progressively decreases.

If Fast Charge is disabled, the voltage is instead set equal to 2.225 V/cell. This is the proper selection in case the Load does not accepts the Fast Charge voltage but only this lower voltage level. Simply leave Fast Charge disabled on dipswitch (7).

Once the current falls below  $I_{max}/8$ , the battery waits for 9 s before entering Float charge mode.

Timeout is set at 300 min. After this time, the charge will automatically transfer to Float charge mode.

### 10.3.4. Float

During Float charge mode, voltage is set at the float voltage level selected by dipswitch for each battery type. This is the long-term condition under which the battery will be safely kept charged during Standby mode.

In case the battery becomes discharged below 2.1 V, the charge will automatically transfer back to Bulk charge mode.

During Float charge mode every 4 hours life test will be performed. If test proves positive, LED signaling and alarm contact will trigger for warning.

## 10.4. Battery Tester function

While in Float charge or when replacing the battery, the DCU battery output can be used as a Battery Tester . By pressing the Battery Start/Test push button for 10s, the DCU will run a full life test. The negative or positive result will be shown by a blinking code on the LEDs. If test indicates that the battery needs to be replaced, please see "Battery Replacement".

Manual Life Test Procedure:

- While in FLOAT mode (all 3 LEDs steady green), keep BATTERY START/TEST push button pressed for 10 s;

- BATTERY LED will flash orange for 3 s. Life test is being performed;
- In case battery is OK > BATTERY LED flashes green for 3 s > after all 3 LEDs go back to FLOAT mode (all 3 LEDs steady green);
- In case battery is KO > BATTERY LED turns red, FAULT LED flashes red 5-pulse sequence.

## 10.5. Battery replacement

Follow these instructions to replace batteries:

1. Switch off the device before replacing the battery;
2. Open the front cover of the battery housing;
3. Remove the fuses (see Figure Error! No text of specified style in document..28b – BBX Battery box Inserting fuse.
- 4.
5. a);
6. Disconnect the battery wiring;
7. Remove the batteries;
8. Install the new batteries;
9. Connect the battery wiring;
10. Install the fuses (see Figure Error! No text of specified style in document..28b – BBX Battery box Inserting fuse.
- 11.
12. b);
13. Close the front cover;
14. Secure the housing to prevent it from being opened;
15. Switch on the DC-UPS.

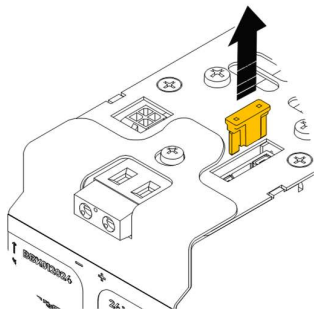

Figure Error! No text of specified style in document..27a – BBX Battery box Removing fuse.

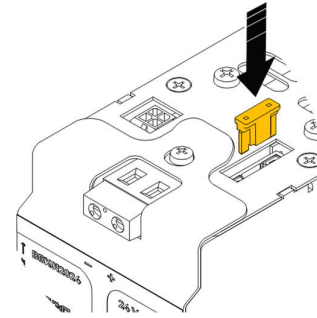

Figure Error! No text of specified style in document..28b – BBX Battery box Inserting fuse.



### WARNING

- When re-connecting the batteries take note of the polarity.
- Do not short circuit the pole terminals.
- The batteries are maintenance free and may not be opened.



### NOTE

When replacing batteries, always use new batteries of the same type.

# 11. Communication

DCU is a fully open device. It communicates via the three channels described below.

## 11.1. LED signals

Three LED indicators are available for visual monitoring of the DC-UPS on the device front. See layout.

- Mains/Backup LED; ( 10 )
- Fault LED; ( 9 )
- Battery LED. ( 8 )

Thanks to blinking code, they provide full set of status and diagnostic information, very useful during installation and on-site inspection. For LED signaling and the corresponding states, please refer to the table below.

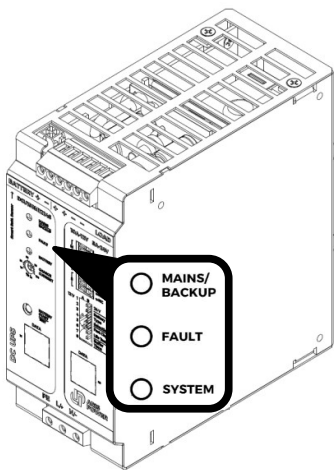

Figure **Error! No text of specified style in document.**29 – Signaling LEDs communication.

## 11.2. Alarm contacts

The DC-UPS is equipped with three built-in alarm contacts. They can be used to forward key alarms to higher-level control system, as follows:

- Mains/Backup; ( M )
- Fault; ( F )
- Rectifier Alarm. ( S )

The three alarms are on dry change-over relay contacts and are brought to push-in terminals on the front of the device. The signal alarm contacts are switched at device power up and will return to rest status when the device is de-energized, according to fail- safe mode

practice. For alarm contacts states, please refer to the table below.

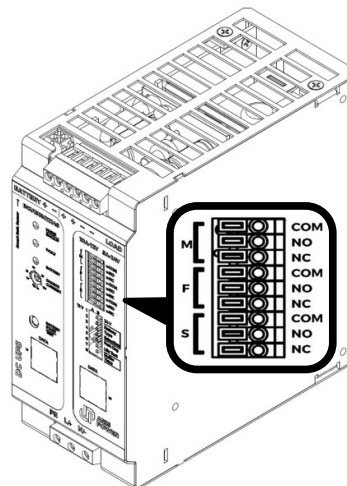

Figure **Error! No text of specified style in document.**30 – Alarm contacts communication.

## 11.3. Modbus-RTU

### DCU150M1224S only

The DC-UPS can communicate with a PLC or a higher-level controller via a serial port on the two RJ45 connectors. The interface is designed for Modbus-RTU communication protocol.

The DC-UPS BATTSAFE firmware includes a full communication interface to allow remote monitoring and control of the system. The device is ready configured to enable communication. Please contact Customer Support for full infos on available set of parameters, communication protocol and Map of Registers

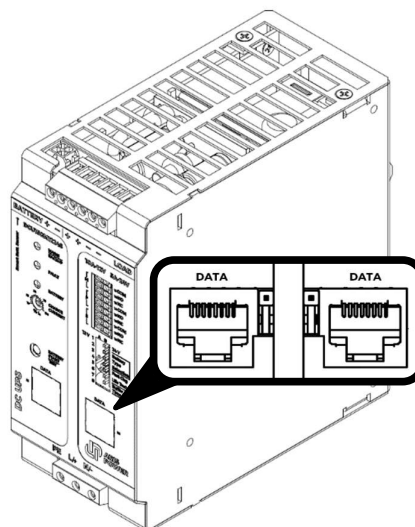















Figure 11.3 - Data Link Communication.

LEDs Signaling Meaning	LEDs											RELAYS		
	Mains/Backup (11)			Fault (10)				Battery (9)				Mains/Backup (M)	Fault (F)	Rectifier Failure (S)
	Red	Orange	Green	Red	Orange	Green	Notes	Red	Orange	Green	Notes			
Device off	○	○	○	○	○	○		○	○	○		OFF	OFF	OFF
Power-Init	○	●	○	○	●	○		○	●	○		ON	ON	ON
Recovery-charge	○	○	●	●	○	○		●	○	○	2 blink / 1 sec 	ON	ON	OFF
Bulk	○	○	●	○	○	●		○	●	○	1 blink / 1 sec 	ON	ON	ON
Absorption	○	○	●	○	○	●		○	●	○	1 blink / 2 sec 	ON	ON	ON
Float	○	○	●	○	○	●		○	○	●		ON	ON	ON
Reverse Polarity	○	○	●	●	○	○	1 pulse 	●	○	○		ON	OFF	OFF
Disconnected Battery	○	○	●	●	○	○	2 pulses 	●	○	○		ON	OFF	OFF
Wrong Battery Voltage	○	○	●	●	○	○	3 pulses 	●	○	○		ON	OFF	OFF
Float, cell in short circuit	○	○	●	●	○	○	4 pulses 	●	○	○		ON	OFF	OFF
Float, Life Test	○	○	●	●	○	○	5 pulses 	●	○	○		ON	OFF	OFF
Low Battery Voltage	○	○	●	●	○	○	6 pulses 	●	○	○		ON	OFF	OFF
Overload or Short circuit on load output	○	○	●	○	●	○	1 pulse 	○	○	○		ON	OFF	ON
Load Boost	○	○	●	○	●	○		○	○	○		ON	OFF	ON
Rectifier fail	○	○	●	○	●	○	3 pulses 	○	○	○		ON	OFF	ON
Wire High impedance	○	○	●	○	●	○	4 pulses 	○	○	○		ON	OFF	OFF
Back-up operation ok	○	●	○	○	○	○		○	○	●		OFF	OFF	ON
Battery almost discharged	○	●	○	○	○	○		○	●	○		OFF	ON	OFF
Battery fully discharged	○	●	○	○	○	○		●	○	○		OFF	ON	ON
Overload or Short circuit on load output during back-up	○	●	○	○	●	○	1 pulse 	○	○	○		ON	OFF	ON

Legend	Color	Green = All good	Orange = Warning	Red = Alarm
	Status	 LED flashing	 LED on	 LED off

## 12. Output Configurations

Besides in Standard configuration described below, DC-UPSs of the same type can be connected in parallel configuration to achieve a desired redundancy level or increase totally available current.

DC-UPSs can also be connected in series to power DC buses with voltage rating higher than those available in the DCU range. Alternatively, series connection can be used to achieve higher currents than at higher voltage.

### 12.1. Standard Output configuration

The standard configuration for all DC-UPS units is as follows.

A DCU unit connected to mains, with Battery output connected to a BBX unit (or customer battery pack) and Load output connected to the buffered DC load via the DC BUS.

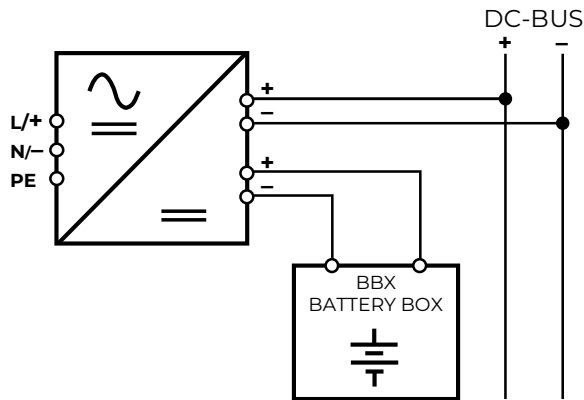

Figure Error! No text of specified style in document..31 – Standard Output configuration.



#### NOTE

Protect the Load output. Design the load circuit to prevent high reverse return voltage (e.g., from a battery or a decelerating motor).

### 12.2. Redundancy Output configuration

Redundant power supply systems are required in applications which demand high reliability in operation. They require multiple DC-UPS units connected in parallel. As an example, 100% redundancy means that in case of one of the DC-UPS units becoming faulty, there will be another one able to meet 100% of load demand without interruption.

To do so, the DC-UPS units to be connected in parallel must be large enough to ensure that the total current requirement of all buffered loads can be fully met by one unit.

The DC-UPS units must be connected to the DC bus through a Decoupling Diodes module, like DCM20. See Figure Error! No text of specified style in document..32.

Each DC-UPS is monitored by the Fault LED on the front. The Fault relay contact reports the alarm to a remote position or logic controller.

As an advantage, 100% redundancy enables to hot-swap the failed DC-UPS and replace it with a new one without system down time.

### 12.3. Series Output configuration

More DCU units of the same type can be connected in series to provide higher voltage rating, as shown in Figure Error! No text of specified style in document..33. However, please consider the following note:



#### NOTE

- In case of three-phase mains, if possible, connect each DC-UPS to different phases
- Use separate primary-side protection for each DC-UPS.

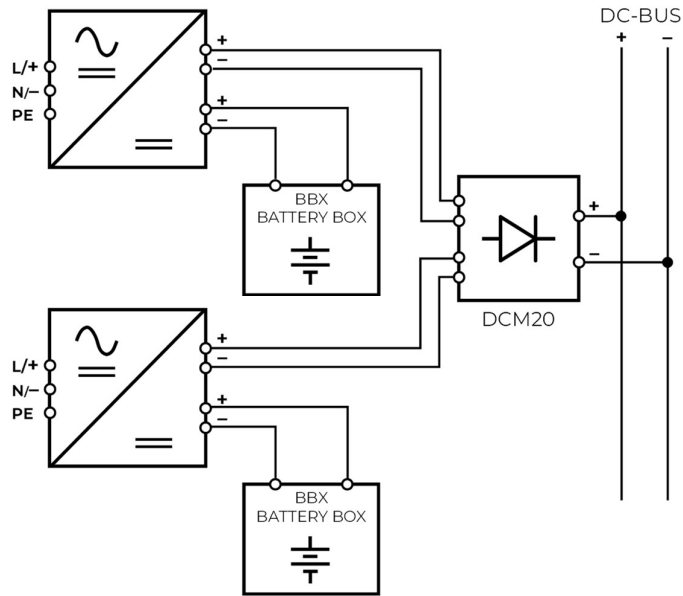

Figure **Error! No text of specified style in document..32** -Redundancy Output configuration.

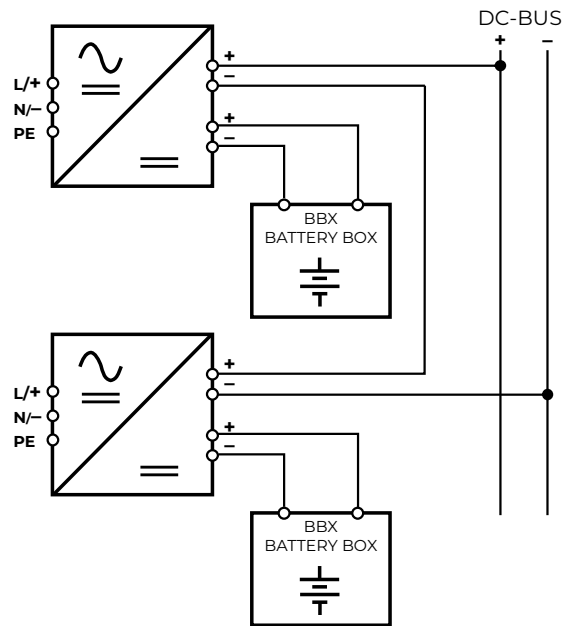

Figure **Error! No text of specified style in document..33** - Series Output configuration.



**NOTE**

- Total output voltage must not exceed 150 Vdc.).
- Circuits with rated voltage above 72 Vdc are not SELV and can be dangerous if not provided with output earthing and earth leakage protection



## 13. Derating

### 13.1. Derating for Ambient temperature

The DC-UPS provides the  $I_n$  nominal current to the load up to +50 °C ambient temperature. At ambient temperatures above +50°C, output current must be decreased by 2.5 %/°C. When ambient temperature exceeds +70°C or in the event of thermal overload, the device does not switch off and continues to supply the load. Output current is automatically reduced to allow safe operation and protection of the DC-UPS.

Once the device cools down, the output is enabled again.

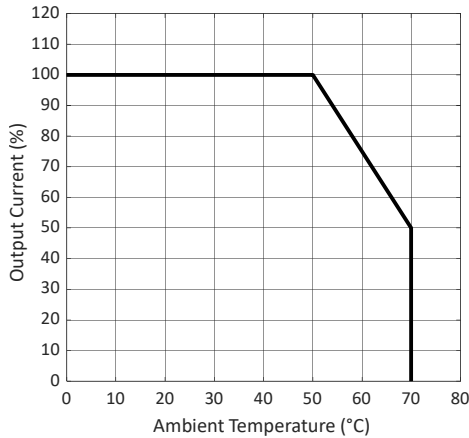

Figure **Error! No text of specified style in document..34** – Temperature derating.

### 13.2. Derating for Elevation above sea level

The DC-UPS can be installed and operated up to 2000 m elevation asl without any limitations and derating. When installed at locations above 2000 m, due to the lower air pressure and the reduced convection cooling associated, a derating will apply as by the chart below.

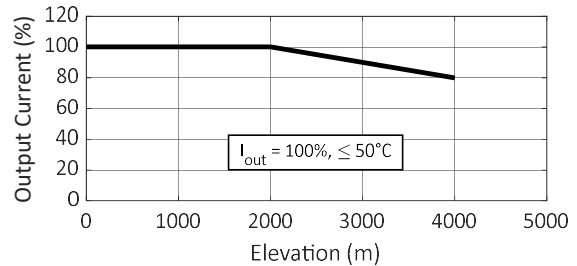

Figure **Error! No text of specified style in document..35** – Elevation derating.

# 14. Technical Data

## General description:

### DCU150M1224 DCU150M1224S

DCU Series - DC-UPS, AC to DC uninterruptable power systems for critical DC loads

All-in-One: Power supply + Battery charger + Back-up functions, all packaged in one box.

- Total power 150W
- Selectable Output Voltage, 12 Vdc or 24 Vdc
- Load-first, Dynamic Load/Battery power sharing
- Adjustable maximum battery charging current.
- Suitable for backup of high inrush current DC loads
- Buffer time setting of load backup
- Universal charging output, selectable Battery Type
- Temperature compensation sensor via UART serial port
- Manual Battery start-up button with no mains
- Battery life test, automatic or via manual button
- Extensive BATTSAFE battery management firmware
- Full set of protection and monitoring functions
- Local monitoring and diagnostics on LEDs
- Remote alarms via 3 voltage-free relay contacts
- Communication via Modbus/CAN bus data link

#### Input

Rated Input Voltage	<b>115/230/277 Vac , 110/220 Vdc</b>	
Input Voltage Range	<b>85-305 Vac , 110-420 Vdc</b>	
Frequency Range	<b>47- 440 Hz</b>	
Input Current (Typ.)	<b>1.6 A (115 Vac), 0.6 A (230 Vac)</b>	
Inrush Current (Typ. Cold Start)	<b>15 A max</b>	
Setup, Rise Time Max	<b>1 s</b>	
Recommended External Fuse/MCB	<b>6 A, curve C</b>	

#### Load Output – Power Supply Mode – Mains ON & Battery OFF

Voltage, selectable by dipswitch <sup>1</sup>	<b>12 Vdc</b>	<b>24 Vdc</b>
Rated Current (I <sub>R</sub> )	<b>10 A</b>	<b>5 A</b>
Ripple / Noise <sup>2</sup>	<b>80 mV<sub>pp</sub></b>	<b>100 mV<sub>pp</sub></b>
Short Circuit Protection	<b>yes</b>	
Overload Protection	<b>Constant Current mode &gt; 110% I<sub>R</sub></b>	
Over Voltage Protection	<b>35 Vdc</b>	

#### Load Output – Standby Mode – Mains ON & Battery ON

Voltage Range, Automatic Set <sup>1</sup>	<b>12-14.4 Vdc</b>	<b>24-28.8 Vdc</b>
Max Continuous Current (I <sub>R</sub> +I <sub>BATT</sub> )	<b>15 A</b>	<b>10 A</b>
Max Current for 30 s	<b>17 A</b>	<b>15 A</b>
Max Current for 15 s	<b>20 A</b>	<b>20 A</b>
Max Current for 5 s	<b>&lt; 25 A</b>	<b>&lt; 25 A</b>

#### Load Output – Backup Mode – Mains OFF & Battery ON

Voltage Range, Automatic Set <sup>1</sup>	<b>9.5-12 Vdc</b>	<b>18.5-24 Vdc</b>
Max Continuous Current (I <sub>R</sub> +I <sub>BATT</sub> )	<b>15 A</b>	<b>10 A</b>
Max Current for 30 s	<b>17 A</b>	<b>15 A</b>
Max Current for 15 s	<b>20 A</b>	<b>20 A</b>
Max Current for 5 s	<b>&lt; 25 A</b>	<b>&lt; 25 A</b>
Time Buffering for Backup	<b>30 s up to ∞</b>	
Start from battery with no mains	<b>Yes, on Push Button</b>	
Quiescent current	<b>&lt; 90 mA</b>	

#### Signal Output/Input

Standby / Backup	<b>Change-over relay contact, M terminals</b>
Common Fault	<b>Change-over relay contact, F terminals</b>
Rectifier failure	<b>Change-over relay contact, S terminals</b>
Full set of monitor and alarm visual signals	<b>Flashing code on 3, Three-color LEDs</b>
Data Link Modbus	<b>Dual RJ45 connector</b>
Temperature Compensation Serial Port	<b>UART connector</b>

## Climatic Data

Operating Ambient Temperature (TA)	<b>-25 up to +70°C</b>
Relative Humidity, no condensation@25°C	<b>max 95%</b>
Storage Temperature	<b>-40 up to +85°C</b>
Cooling	<b>Natural Convection</b>

## General Data

Efficiency (Typ.)	<b>&gt;90%</b>	<b>&gt;92%</b>
Temperature Derating Factor 1	<b>2.5 %/°C , T<sub>A</sub> &gt; 50°C</b>	
Altitude Derating Factor 1	<b>0.5°C/100 m, above 2000 m</b>	
Insulation Voltage (In/Out)	<b>4 kVac</b>	
Insulation Voltage (In/PE)	<b>2 kVac</b>	
Insulation Voltage (Out/PE)	<b>500 Vdc</b>	
Insulation Resistance (500 V)	<b>&gt; 100 MΩ</b>	
Protection Class (EN/IEC 60529)	<b>IP 20</b>	
Pollution Degree Environment	<b>2</b>	
Dimensions (W x H x D)	<b>60 x 130 x 126 mm</b>	
Weight	<b>0.65 kg</b>	

## Norms and certifications - Conformity

Electrical Safety	Low Voltage Directive 2014/35/EU, 2014/35/UE as follow: EN60950-1, (UL60950-1, UL508, C22.2, EN60335-2-29, UL1236), EN IEC 62368-1:2014/AC:2015;
EMC Emission	EN55011 (CISPR11), EN55022 (CISPR22) Class B, EN61000-3-2,3
EMC Immunity	EN61000-4-2,3,4,5,6,8,11
Fire Detection and fire alarm systems	EN54-4
Battery chargers	IEC/EN 60335-2-29
Charging cycle	DIN41773
UL Pending	

## Battery Management

Rated Voltage	<b>12 Vdc</b>	<b>24 Vdc</b>
Charging Curve	<b>3 stages (IUoU) + Recovery</b>	
Charging Current setting (min/max)	<b>1.0 A / 10.0 A</b>	<b>0.5 A / 5.0 A</b>
Battery Type, selectable by dipswitch	<b>Vented &amp; Sealed Lead Acid, AGM, Li-Io, Li-PoFe, NiCd</b>	
Voltage max	<b>14.75 Vdc</b>	<b>29.50 Vdc</b>
Boost Voltage	<b>14.4 Vdc</b>	<b>28.8 Vdc</b>
Float Voltage, dipswitch selectable	<b>According to battery type</b>	
Recovery Charge	<b>2-10 Vdc</b>	<b>2-20 Vdc</b>
Low Voltage Disconnect (LVD) Threshold	<b>9.3 Vdc</b>	<b>18.5 Vdc</b>
Low Voltage Alarm Threshold	<b>11 Vdc</b>	<b>22 Vdc</b>
Time Boost-Bulk Charge (Typ. IN)	<b>min 5 s, max 15 h</b>	
Temperature Compensation	<b>Digital sensor on UART Serial port</b>	
Boost voltage Enable/Disable	<b>Local dipswitch or Remote Link</b>	
Protections	<b>Reverse Polarity, Disconnected Battery Wrong Battery Voltage Sulphated Battery, Cell-In Short Circuit</b>	
Battery Diagnostics		
Life Test	<b>Automatic Every 2 h in Standby, Manual on Push Button</b>	